

VMAL FIRE FIGHTING PRODUCTS



ValveLink Europe Ent



1. 200PSI-OS&Y Type Flanged End Gate Valve Model No:Z41	3
2. 200PSI-OS&Y Type Flanged Grooved Gate Valve Model No:Z481	4
3. 200PSI-OS&Y Type Grooved End Gate Valve Model No:Z81	5
4. 200PSI-NRS Type Flanged Gate Valve Model No:Z45B	6
5. 200PSI-NRS Type Flanged End Gate Valve With Round Plate Model No: Z45.....	7
6. 200PSI-NRS Type Flanged Grooved Gate Valve Model No: Z485	8
7. 200PSI-NRS Type Grooved End Gate Valve Valve Model No: Z85	9
8. 300PSI-OS&Y Type Flanged End Gate Valve Model No: Z41-300.....	10
9. 300PSI-OS&Y Type Flanged End Gate Valve Model No: Z45-300.....	11
10. 300PSI- Flanged End Swing Check Valve Model No: XQH-300	12
11. Vertical Type Indicator Post Model No: ZSQ	13
12. Wall Type Indicator Post Model No: QSCZG	14
13. Wafer Type Butterfly Valve,UL,ULC Listed, FM Approved Model No:WD-371X.....	15
14. Grooved Type Butterfly Valve,UL,ULC Listed, FM Approved Model No:GD-381X.....	16
15. Dry Barrel Fire Hydrant Model No:MH-1510.....	17

200PSI-OS&Y Type Flanged End Gate Valve

Model No:Z41



Technical Specifications:

- 1.Design Standard:AWWA C515
- 2.Nominal Pressure:200PSI
- 3.Flange Standard:ANSI B16.1 Class125 or according to the customer's requirements
- 4.Both inside and outside of the body need Epoxy Resin Coating

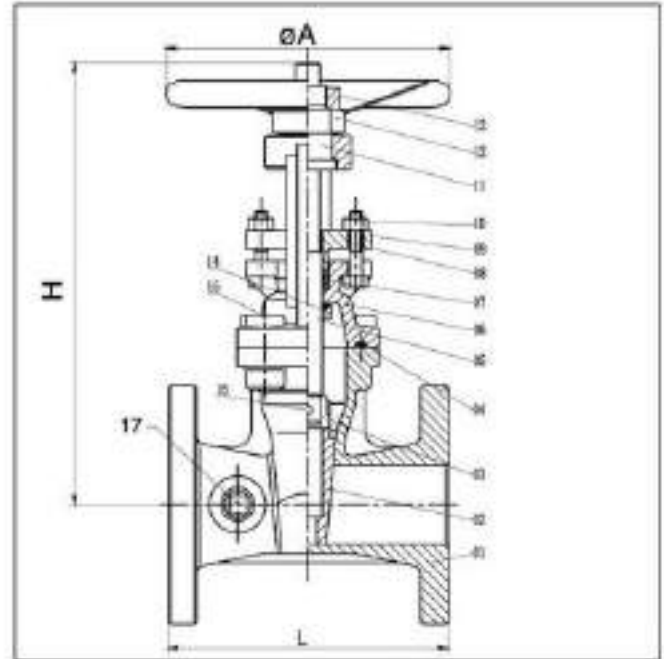

SIZE CHART

SIZE ITEM	2"	2-1/2"	3"	4"	5"	6"	8"	10"	12"
L	178	190	203	229	254	267	292	330	356
H	280	310	370	428	532	590	735	908	1150
øA	180	220	250	280	300	350	380	450	450

17	Plug	2	Cast Bronze	ASTM B62
16	Cylinder Pin	1	Steel	
15	Countersunk Head Bolt	4	Steel	
14	Flat Key	1	S.S.416	
13	Lock Nut	1	Steel	ANSI 1045
12	Handwheel	1	Steel	ANSI 1045
11	Rotating Nut	1	C95400	ASTM B148
10	Nut	2	Steel	
09	Platen	1	DI	ASTMA536 65-45-12
08	Bolt	2	Steel	
07	Sealing Kits	3	PTFE	ASTM D4745
06	Cap	1	DI	ASTMA536 65-45-12
05	Stem	1	S.S.304	ASTM A276
04	Sealing Pad	1	EPDM	ASTM D2000 EPDM
03	Connecting Part	1	C95400	ASTM B148
02	Disc	1	DI-EPDM	ASTM A536 65-45-12 + EPDM
01	Body	1	DI	ASTMA536 65-45-12
No.	Name	Qty.	Material	Remark

200PSI-OS&Y Type Flanged Grooved Gate Valve

Model No:Z481



Technical Specifications:

- 1.Design Standard:AWWA C515
- 2.Nominal Pressure:200PSI
- 3.Flange Standard:ANSI B16.1 Class125 or according to the customer's requirements
- 4.Groove Standard:Metric or AWWA C506
- 5.Both inside and outside of the body need Epoxy Resin Coating

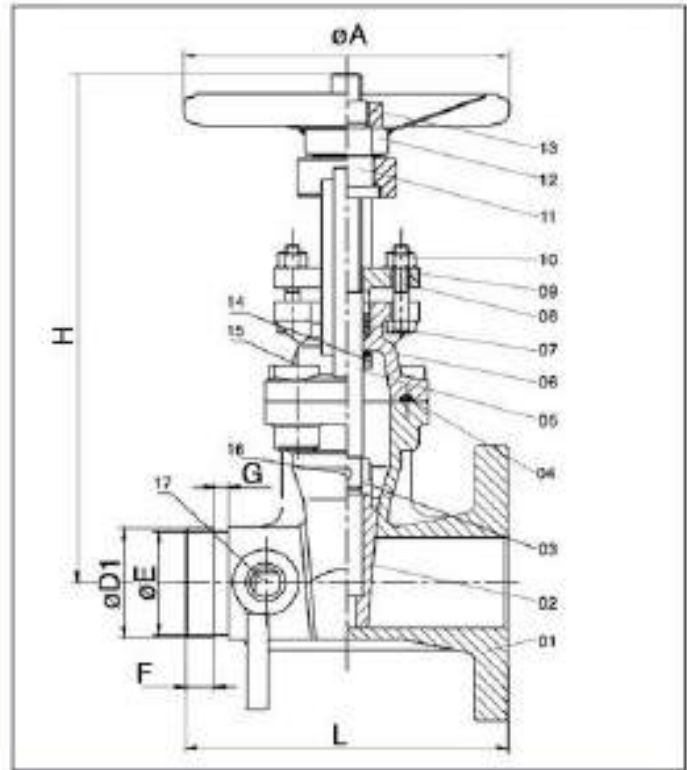

SIZE CHART

SIZE	2"	2-1/2"	3"	4"	5"	6"	8"	10"	12"
L	178	190	203	229	254	287	292	330	356
H	280	310	370	428	532	590	735	908	1150
øA	180	220	250	280	300	350	380	450	450
øD1	60.3	76.1	88.9	114.3	141.3	168.3	219.1	273	323.9
øE	57.2	72.3	84.9	110.1	137	163.8	214.4	268.3	318.3
F	15.9	15.9	15.9	15.9	15.9	15.9	19	19	19
G	7.9	7.9	7.9	9.5	9.5	9.5	11.1	12.7	12.7

17	Plug	2	Cast Bronze	ASTM B62
16	Cylinder Pin	1	Steel	
15	Countersunk Head Bolt	4	Steel	
14	Flat Key	1	Steel	
13	Lock Nut	1	Steel	ANSI 1045
12	Handwheel	1	Steel	ANSI 1045
11	Rotating Nut	1	Cast Bronze	ASTM B62
10	Nut	2	Steel	ASTM A307 B
09	Platen	1	DI	ASTMA536 65-45-12
08	Bolt	2	Steel	
07	Sealing Kits	3	PTFE	ASTM D4745
06	Cap	1	DI	ASTMA536 65-45-12
05	Stem	1	S.S.304	ASTM A276
04	Sealing Pad	1	EPDM	ASTM D2000 EPDM
03	Connecting Part	1	C95400	ASTM B148
02	Disc	1	DI+EPDM	ASTM A536 65-45-12 +EPDM
01	Body	1	DI	ASTM A536 65-45-12
NO.	Name	Qty.	Material	Remark

200PSI-OS&Y Type Grooved End Gate Valve

Model No:Z81



Technical Specifications:

- 1.Design Standard:AWWA C515
- 2.Nominal Pressure:200PSI
- 3.Groove Standard:Metric or AWWA C606
- 4.Both inside and outside of the body need Epoxy Resin Coating

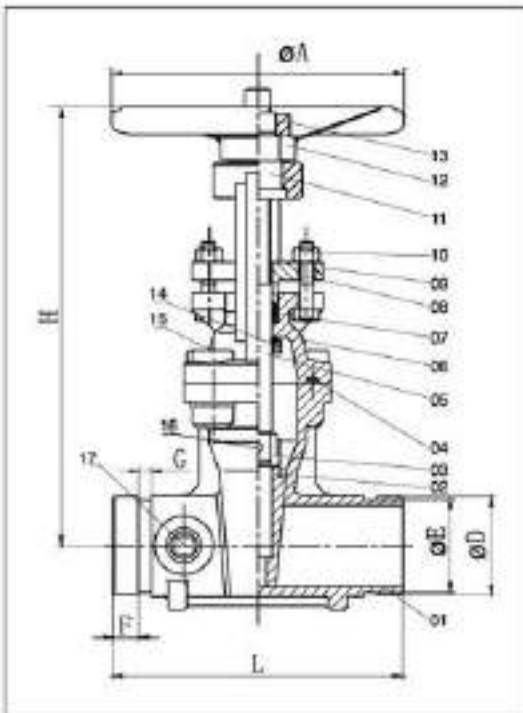

SIZE CHART

SIZE	2"	2-1/2"	3"	4"	5"	6"	8"	10"	12"
L	178	190	203	229	254	267	292	330	358
H	280	310	370	428	532	590	735	905	1150
eA	180	220	250	280	300	350	380	450	450
eD	60.3	76.1	88.9	114.3	141.3	168.3	219.1	273	323.9
eE	57.2	72.3	84.9	110.1	137	163.9	214.4	268.3	318.3
F	15.9	15.9	15.9	15.9	15.9	15.9	19	19	19
G	7.9	7.9	7.9	9.5	9.5	9.5	11.1	12.7	12.7

17	Plug	2	Cast Bronze	ASTM B62
16	Cylinder Pin	1	Steel	
15	Countersunk Head Bolt	4	Steel	
14	Flat Key	1	S.S.416	ASTM A276
13	Lock Nut	1	Steel	ANSI 1045
12	Handwheel	1	Steel	ANSI 1045
11	Rotating Nut	1	C95400	ASTM B148
10	Nut	2	Steel	
09	Platen	1	DI	ASTM A536 65-45-12
08	Bolt	2	Steel	ASTM A307 B
07	Sealing Kits	3	PTFE	ASTM D4745
06	Cap	1	DI	ASTM A536 65-45-12
05	Stem	1	S.S.304	ASTM A276
04	Sealing Pad	1	EPDM	ASTM D2000 EPDM
03	Connecting Part	1	C95400	ASTM B148
02	Disc	1	DI+EPDM	ASTM A536 65-45-12 + EPDM
01	Body	1	DI	ASTM A536 65-45-12
NO.	Name	Qty.	Material	Remark

200PSI-NRS Type Flanged Gate Valve

Model No:Z45B



Technical Specifications:

- 1.Design Standard:AWWA C515
- 2.Nominal Pressure:200PSI
- 3.Flange Standard:ANSI B16.1 Class125 or according to the customer's requirements
- 4.Both inside and outside of the body need Epoxy Resin Coating

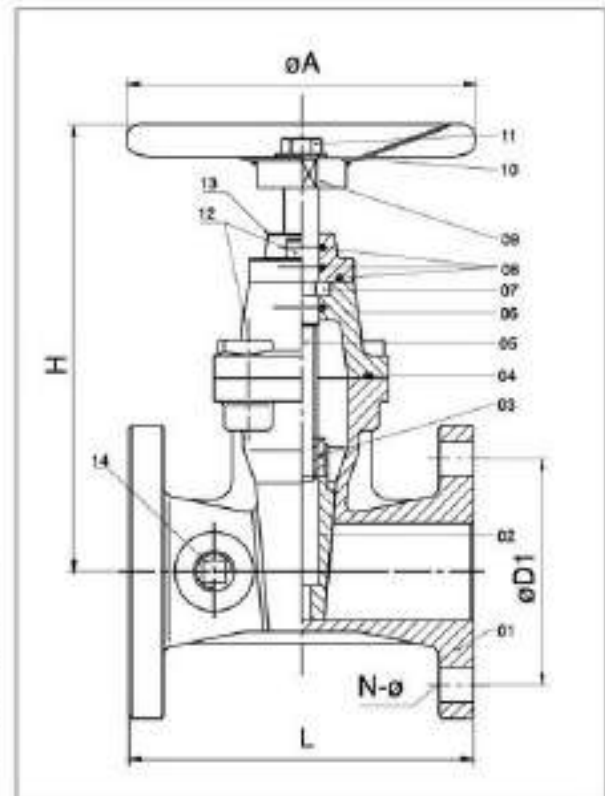

SIZE CHART

SIZE ITEM	2-1/2"	3"	4"	5"	6"	8"	10"	12"
L	190	203	229	254	267	292	330	356
H	255	289	323	366	420	520	626	725
øD1	139.5	152.5	190.5	216	241.5	296.5	362	432
N-ø	4-19	4-19	8-19	8-22	8-22	8-22	12-25	12-25
øA	220	250	280	300	350	360	450	450

14	Plug	2	Cast Bronze	ASTM B62
13	Platen	1	DI	ASTM A536 65-45-12
12	Countersunk Head Bolt	n	Steel	
11	Bolt	1	Steel	
10	Flat Gasket	1	Steel	
09	Handwheel	1	Steel	ANSI 1045
08	O-Ring	2	EPDM	NBR
07	Retainer Ring	1	Cast Bronze	ASTM B62
06	Cap	1	DI	ASTM A536 65-45-12
05	Stem	1	Stainless Steel	SS420
04	Gasket	1	EPDM	NBR
03	Nut	1	Cast Bronze	ASTM B62
02	Disc	1	DI+EPDM	ASTM A536 65-45-12
01	Body	1	DI	ASTM A536 65-45-12
NO.	Name	Qty.	Material	Remark



Technical Specifications:

- 1.Design Standard:AWWA C515
- 2.Nominal Pressure:200PSI
- 3.Flange Standard:ANSI B16.1 Class125 or according to the customer's requirements
- 4.Both inside and outside of the body need Epoxy Resin Coating
- 5.It could also be operated by the handwheel

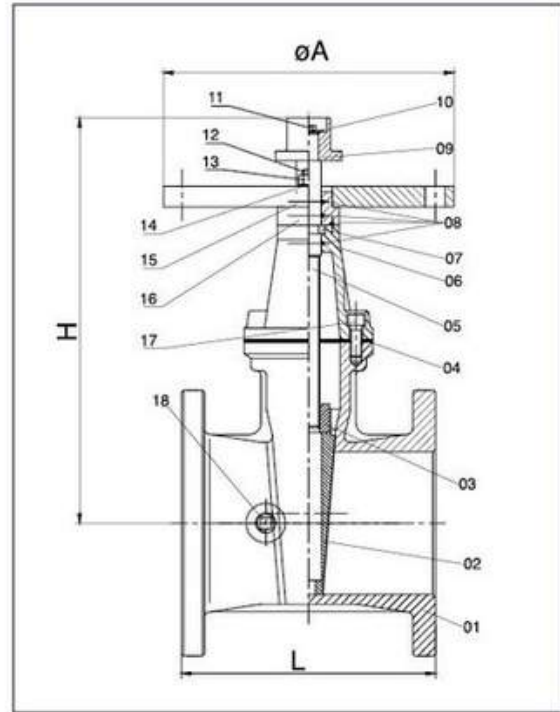

SIZE CHART

SIZE ITEM	2-1/2"	3"	4"	5"	6"	8"	10"	12"
L	190	203	229	254	267	292	330	356
H	255	289	323	386	420	520	628	725
øA	305	305	305	305	305	305	305	305

18	Plug	2	Cast Bronze	ASTM B62
17	Countersunk Head Bolt	1	Steel	
16	Platen	1	DI	ASTM A536 65-45-12
15	Coupling Flange	2	DI	ASTM A536 65-45-12
14	Plain Washer	2	Steel	
13	Blind Nut	2	Steel	
12	Bolt Stud	1	Steel	
11	Bolt	1	Steel	
10	Minipad	1	Steel	
09	Scotch	1	DI	ASTM A536 65-45-12
08	O-Ring	3	EPDM	ASTM D2000 EPDM
07	Retainer Ring	1	C95400	ASTM B148
06	Cap	1	DI	ASTM A536 65-45-12
05	Stem	1	S.S.304	ASTM A276
04	Gasket	1	EPDM	ASTM D2000 EPDM
03	Nut	1	C95400	ASTM B148
02	Disc	1	DI+EPDM	ASTM A536 65-45-12 + EPDM
01	Body	1	DI	ASTM A536 65-45-12
NO.	Name	Qty.	Material	Remark

200PSI-NRS Type Flanged Grooved Gate Valve

Model No:Z485



Technical Specifications:

1. Design Standard: AWWA C515
2. Nominal Pressure: 200PSI
3. Flange Standard: ANSI B16.1 Class125 or according to the customer's requirements
4. Groove Standard: Metric or AWWA C606
5. Both inside and outside of the body need Epoxy Resin Coating
6. It could also be operated by the handwheel

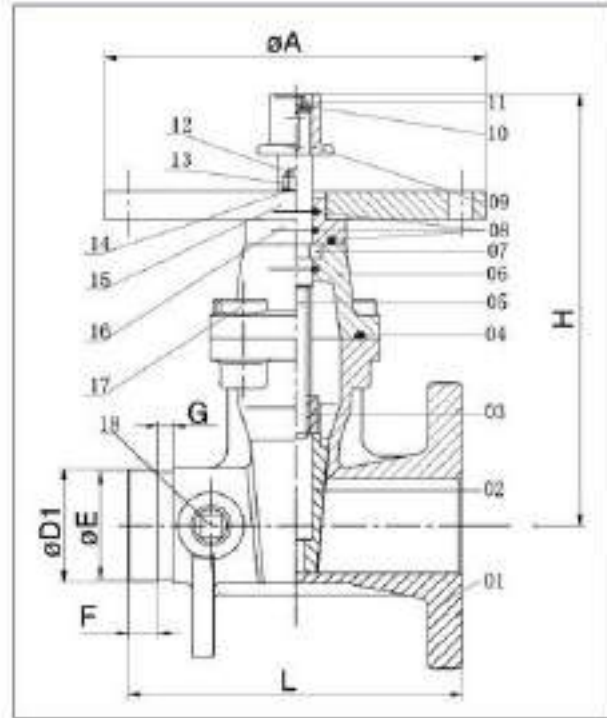

SIZE CHART

SIZE	2-1/2"	3"	4"	5"	6"	8"	10"	12"
L	190	203	229	254	267	292	330	366
H	255	289	323	386	420	520	628	725
øD1	76.1	88.9	114.3	141.3	168.3	219.1	273	323.9
øE	72.3	84.9	110.1	137	163.9	214.4	268.3	318.3
F	15.9	15.9	15.9	15.9	15.9	19	19	19
G	7.9	7.9	9.5	9.5	9.5	11.1	12.7	12.7
øA	305	305	305	305	305	305	305	305

18	Plug	2	Cast Bronze	
17	Countersunk Head Bolt	n	Steel	
16	Platen	1	DI	ASTM A536 65-45-12
15	Coupling Flange	2	DI	ASTM A536 65-45-12
14	Plain Washer	2	Steel	
13	Blind Nut	2	Steel	
12	Bolt Stud	1	Steel	
11	Bolt	1	Steel	
10	Minipad	1	Steel	
09	Scotch	1	DI	ASTM A536 65-45-12
08	O-Ring	2	EPDM	ASTM D2000 EPDM
07	Retainer Ring	1	C2800	ASTM B135
06	Cap	1	DI	ASTM A536 65-45-12
05	Stem	1	S.S.304	ASTM A276
04	Gasket	1	EPDM	ASTM D2000 EPDM
03	Nut	1	C95400	ASTM B148
02	Disc	1	DI+EPDM	ASTM A536 65-45-12 + EPDM
01	Body	1	DI	ASTM A536 65-45-12
NO.	Name	Qty.	Material	Remark

200PSI-NRS Type Grooved End Gate Valve

Model No: Z85



Technical Specifications:

- 1.Design Standard:AWWA C515
- 2.Nominal Pressure:200PSI
- 3.Flange Standard:ANSI B16.1 Class125 or according to the customer's requirements
- 4.Both inside and outside of the body need Epoxy Resin Coating
- 5.It could also be operated by the handwheel

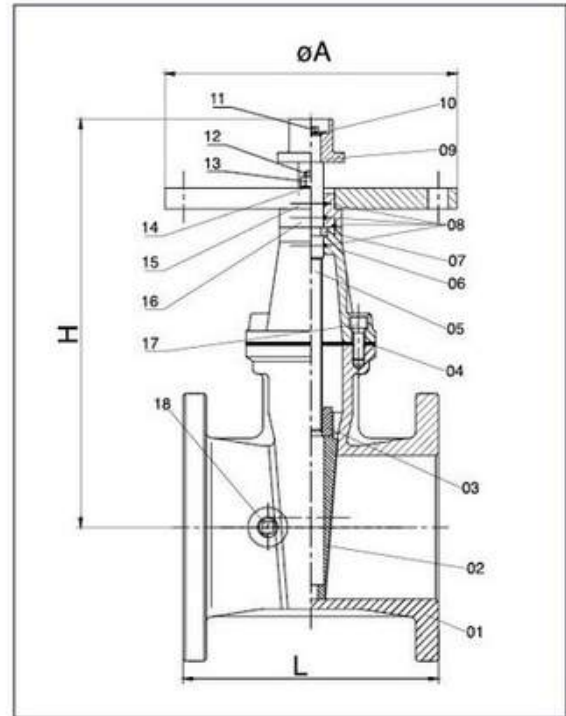

SIZE CHART

SIZE ITEM	2-1/2"	3"	4"	5"	6"	8"	10"	12"
L	190	203	229	254	267	292	330	356
H	255	289	323	386	420	520	628	725
øA	305	305	305	305	305	305	305	305

18	Plug	2	Cast Bronze	ASTM B62
17	Countersunk Head Bolt	1	Steel	
16	Platen	1	DI	ASTM A536 65-45-12
15	Coupling Flange	2	DI	ASTM A536 65-45-12
14	Plain Washer	2	Steel	
13	Blind Nut	2	Steel	
12	Bolt Stud	1	Steel	
11	Bolt	1	Steel	
10	Minipad	1	Steel	
09	Scotch	1	DI	ASTM A536 65-45-12
08	O-Ring	3	EPDM	ASTM D2000 EPDM
07	Retainer Ring	1	C95400	ASTM B148
06	Cap	1	DI	ASTM A536 65-45-12
05	Stem	1	S.S.304	ASTM A276
04	Gasket	1	EPDM	ASTM D2000 EPDM
03	Nut	1	C95400	ASTM B148
02	Disc	1	DI+EPDM	ASTM A536 65-45-12 + EPDM
01	Body	1	DI	ASTM A536 65-45-12
NO.	Name	Qty.	Material	Remark

300PSI-OS&Y Type Flanged End Gate Valve

Model No: Z41-300



Technical Specifications:

- 1.Design Standard:AWWA C515
- 2.Nominal Pressure:200PSI
- 3.Flange Standard:ANSI B16.1 Class125 or according to the customer's requirements
- 4.Groove Standard:Metric or AWWA C606
- 5.Both inside and outside of the body need Epoxy Resin Coating
- 6.It could also be operated by the handwheel

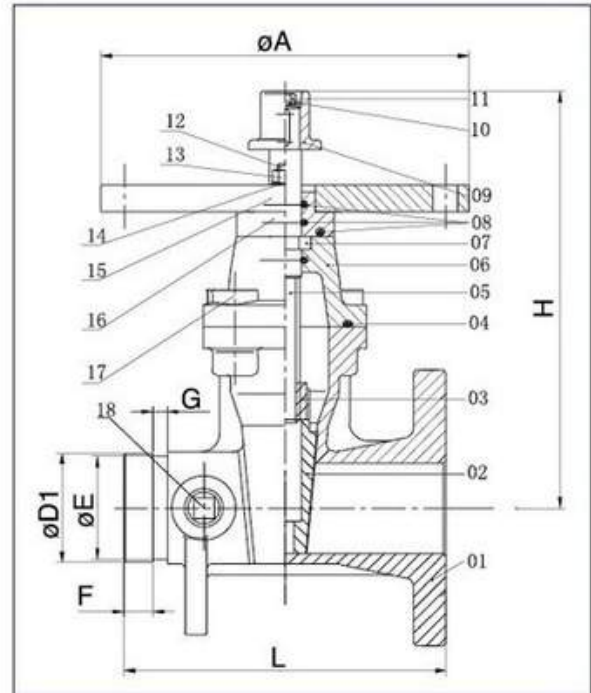

SIZE CHART

SIZE ITEM	2-1/2"	3"	4"	5"	6"	8"	10"	12"
L	190	203	229	254	267	292	330	356
H	255	289	323	386	420	520	628	725
øD1	76.1	88.9	114.3	141.3	168.3	219.1	273	323.9
øE	72.3	84.9	110.1	137	163.9	214.4	268.3	318.3
F	15.9	15.9	15.9	15.9	15.9	19	19	19
G	7.9	7.9	9.5	9.5	9.5	11.1	12.7	12.7
øA	305	305	305	305	305	305	305	305

18	Plug	2	Cast Bronze	
17	Countersunk Head Bolt	n	Steel	
16	Platen	1	DI	ASTM A536 65-45-12
15	Coupling Flange	2	DI	ASTM A536 65-45-12
14	Plain Washer	2	Steel	
13	Blind Nut	2	Steel	
12	Bolt Stud	1	Steel	
11	Bolt	1	Steel	
10	Minipad	1	Steel	
09	Scotch	1	DI	ASTM A536 65-45-12
08	O-Ring	2	EPDM	ASTM D2000 EPDM
07	Retainer Ring	1	C2800	ASTM B135
06	Cap	1	DI	ASTM A536 65-45-12
05	Stem	1	S.S.304	ASTM A276
04	Gasket	1	EPDM	ASTM D2000 EPDM
03	Nut	1	C95400	ASTM B148
02	Disc	1	DI+EPDM	ASTM A536 65-45-12 + EPDM
01	Body	1	DI	ASTM A536 65-45-12
NO.	Name	Qty.	Material	Remark

300PSI-OS&Y Type Flanged End Gate Valve

Model No: Z45-300



Technical Specifications:

- 1.Design Standard:AWWA C515
- 2.Norminal Pressure:300PSI
- 3.Flange Standard:ANSI B16.1 Class125 or according to the customer's requirements
- 4.Both inside and outside of the body need Epoxy Resin Coating
- 5.It could also be operated by the handwheel

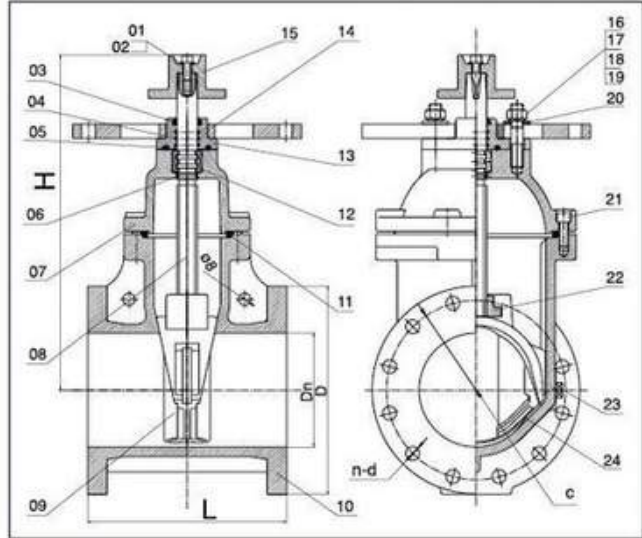

SIZE CHART

SIZE ITEM	2-1/2"	3"	4"	5"	6"	8"	10"	12"
Dn	65	80	103	128.5	155	204	255	304
L	190	203	229	254	267	292	330	356
D	178	191	229	254	279	343	406	483
c	139.5	152.5	190.5	216	241.5	298.5	362	432
n-d	4-ø19	4-ø19	8-ø19	8-ø22	8-ø22	8-ø22	12-ø25	12-ø25
H	292	322	342	412	448	534	635	720

24	Skeleton	1	DI
23	Plug	2	C95400
22	Masterscrew	1	C95400
21	Inner Hexagon Screw	n	Steel
20	Washer	n	Steel
19	Washer	n	Steel
18	Spring Washer	n	Steel
17	Studs	n	S.S.304
16	Nut	n	S.S.304
15	Link Block	1	DI
14	Terminal Pad	1	DI
13	Gland	1	DI
12	Retaining Ring	2	C95400
11	Sealing Ring	1	EPDM
10	Body	1	DI
09	Disc	1	EPDM+DI
08	Stem	1	S.S.304
07	Bonnet	1	DI
06	O-Ring	1	EPDM
05	Sealing Ring	1	EPDM
04	O-Ring	3	EPDM
03	Sealing Gland	1	EPDM
02	Inner Hexagon Screw	1	S.S.304
01	Fiat Washer	1	S.S.304
NO.	Name	Qty.	Material

300PSI- Flanged End Swing Check Valve

Model No: XQH-300



Technical Specifications:

- 1.Design Standard:AWWA C508
- 2.Nominal Pressure:300PSI
- 3.Flange Standard:ANSI B16.1 Class125 or according to the customer's requirements
- 4.Both inside and outside of the body need Epoxy Resin Coating

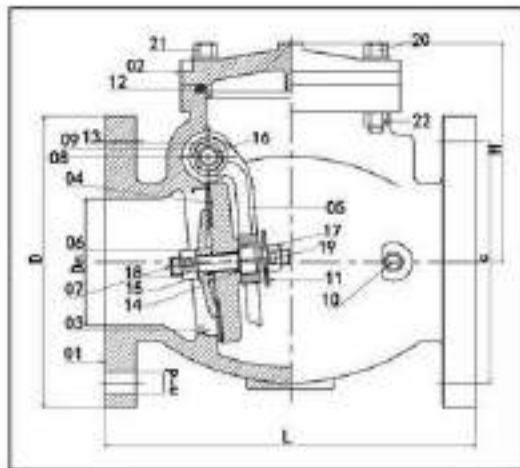

SIZE CHART

SIZE ITEM	2"	2-1/2"	3"	4"	5"	6"	8"	10"	12"
Dn	51	64	80	100	125	152	204	254	302
L	203	218	241	292	330	356	495	622	698
D	152	178	191	229	254	278	343	406	483
e	120.5	139.5	152.5	190.5	216	241.5	298.5	362	432
n-d	4-ø19	4-ø19	4-ø19	8-ø19	8-ø22	8-ø22	8-ø22	12-ø25	12-ø25
H	142	148	163.5	172	237	233	301	348	419

NO.	Name	Material/Standard	Remark
1	Body	ASTM A536 65-45-12	
2	Bonnet	ASTM A536 65-45-12	
3	Seat Ring	ASTM A148 C95400	
4	Disc	ASTM A536 65-45-12	
5	Rocker Arm	ASTM A536 65-45-12	
6	Baffle Plate	ASTM A148 C95400	
7	Middle Stem	ASTM A276 SS304	
8	Pinned Stem	ASTM A276 SS304	
9	Bracket Screw	ASTM A351 SS304	No show in drawing
10	Plug	ASTM A148 C95400	
11	Gasket	ASTM A276 SS304	
12	O-Ring (large)	ASTM D2000 EPDM	
13	O-Ring (for bracket screw)	ASTM D2000 EPDM	No show in drawing
14	O-Ring (for mid stem)	ASTM D2000 EPDM	
15	O-Ring (for mid stem small)	ASTM D2000 EPDM	
16	Bronze bushing	powder metallurgy	No show in drawing
17	SS304 Outer Hexagon Nut M12	ASTM A276 SS304	
18	SS304 Outer Hexagon Nut M12	ASTM A276 SS304	
19	SS304 Cotter Pin 4x55	ASTM A276 SS304	
20	*M12x60 Zinc Outer Hexagon Bolt (half thread) *	STEEL	
21	*M12x40 Zinc Outer Hexagon Bolt (full thread) *	STEEL	
22	M12 Zinc Outer Hexagon Nut	STEEL	

Vertical Type Indicator Post

Model No: ZSQ



Technical Specifications:

1. Unload the upper cover of control lead
2. Measure control lead depth, remove the excess part of connector lead and driving rod
3. Fit the control rod with full closed valve, turn the position plate to SHUT position
4. Load upper cover

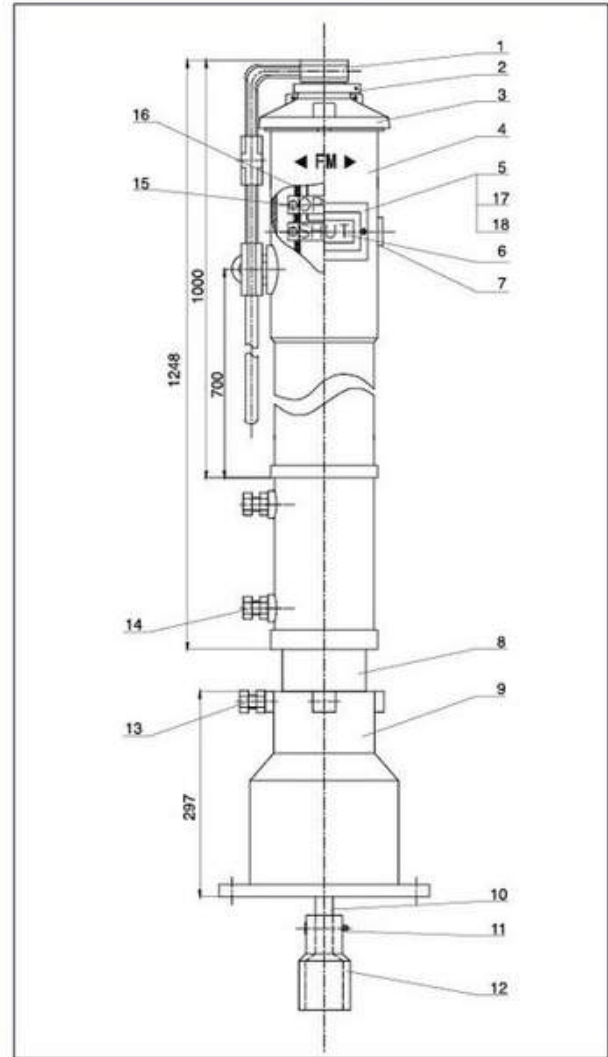

NO.	Name	Material	REMARK
1	Handle	DI	ASTM A536
2	Driving Rod	S.S.304	ASTM A276
3	Indicator Cover	CI	ASTM A126
4	Housing	CI	ASTM A126
5	Keyhole Plate	A283 Gr.C	ASTM A36
6	Indicator Plate	A413.0	ASTM S12A
7	Screwed Plug	1035	ASTM A449
8	Extension Rod	A283 Gr.C	ASTM A36
9	Flange	CI	ASTM A126
10	Connecting Rod	1045	ASTM A29
11	Cotter Pin	1035	ASTM A449
12	Joint	CI	ASTM A126
13	Bolt	1035	ASTM A449
14	Bolt	1035	ASTM A449
15	Bolt	1035	ASTM A449
16	Driving Nut	S.S.304	ASTM A276
17	Keyhole Plate Gasket	EPDM	ASTM D2000
18	Indicator Flap	Organic glass	



Installation instructions :

1. Unload the upper cover of control lead
2. Measure control lead depth, remove the excess part of connector lead and driving rod
3. Fit the control rod with full closed valve, turn the position plate to SHUT position
4. Load upper cover

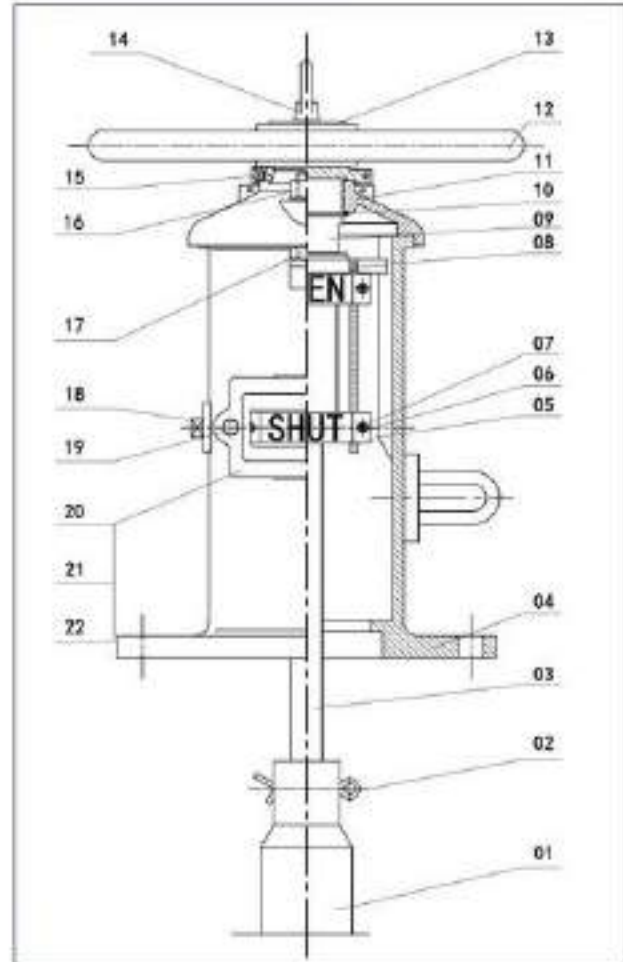

22	Keyhole Plate Gasket	2	EPDM	ASTM D2000
21	Keyhole	2	Organic glass	
20	Keyhole Plate	2	A283 Gr.c	ASTM A36
19	Bolt. Flat Gasket	4	S.S.304	ASTM A276
18	Screwed Plug	1	1035	ASTM A449
17	Bolt	2	1035	ASTM A449
16	Nut	2	1035	ASTM A449
15	Screw	1	1035	ASTM A449
14	Lift Ring	1	1035	ASTM A449
13	Gasket	1	A283 Gr.c	ASTM A36
12	Handwheel	1	CI	ASTM A125
11	Upper Cover	1	CI	ASTM A125
10	Retainer Ring For Stem	1	1566	ASTM A20
09	Driver	1	S.S.304	ASTM A276
08	Position Bracket	1	S.S.304	ASTM A276
07	Stud Bolt	4	1035	ASTM A449
06	Nut,Gasket	4	1035	ASTM A449
05	Indicator Plate	4	A413.0	ASTM S12A
04	Main Body	1	CI	ASTM A125
03	Driving Rod	1	1045	ASTM A29
02	Cotter Pin	1	1035	ASTM A449
01	Joint	1	CI	ASTM A125
NO.	Name	Qty.	Material	Remark

Wafer Type Butterfly Valve, UL, ULC Listed, FM Approved Model No: WD-371X



Working Pressure: 300PSI (21 Bars)

Working Temp: -20°C ~ 110°C (-4°F ~ 230°F)

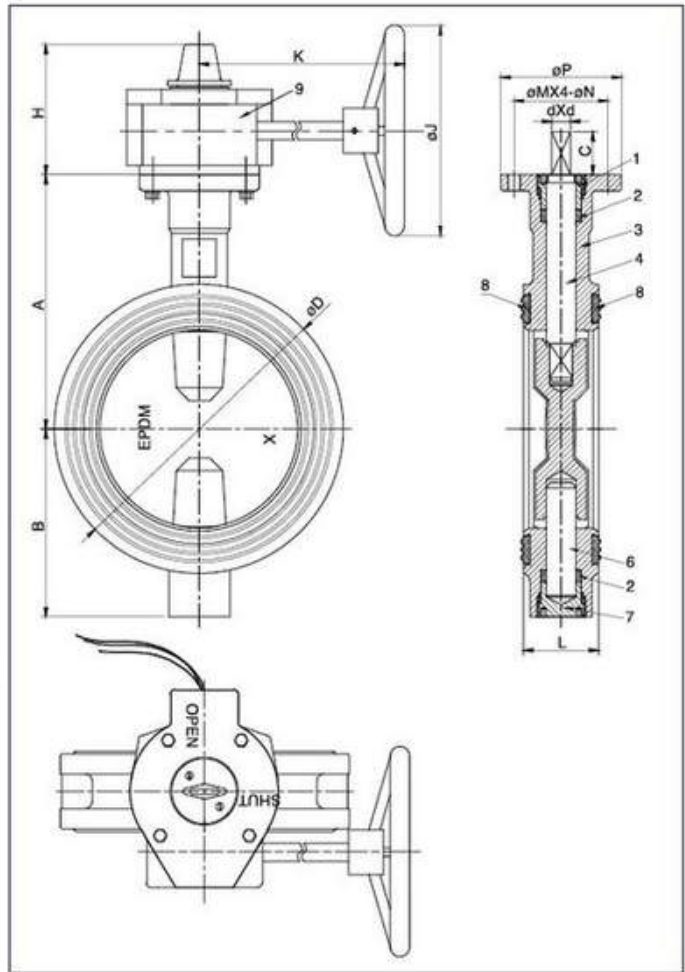

SIZE CHART

ITEM SIZE	A	B	C	D	H	K	J	P	M	N	d	L
2-1/2"	125	95	32	112	111	218	152	90	70	9	10	44.2
3"	140	100	32	120	111	218	152	90	70	9	11	45.3
4"	160	100	32	165	111	218	152	90	70	9	14	52
5"	170	125	32	182	111	218	152	90	70	9	14	54.4
6"	190	140	32	216	111	218	200	90	70	9	16	55.8
8"	230	175	32	260	126	232	300	125	102	12	19	60.5
10"	260	200	45	320	126	232	300	125	102	12	22	66.5
12"	300	240	45	375	161	252	350	150	125	14	24	76.9

Carried Standard	
Design Standard	API609
Face to Face Standard	ASME B16.1
Top Standard	ISO 5211
Test Standard	API598

NO.	Name	Material
09	Signal Gearbox	DI
08	End Face Seal	EPDM
07	Lower Shaft Sealing Nut	WCB
06	Lower Shaft	SS416
05	Disc	DI+EPDM
04	Upper Shaft	SS416
03	Body	DI
02	Shaft Seal	EPDM
01	Upper Shaft Sealing Nut	WCB

Grooved Type Butterfly Valve, UL, ULC Listed, FM Approved Model No:GD-381X



Working Pressure:300PSI(21Bars)
Working Temp:-20℃~110℃(-4 F~230 F)

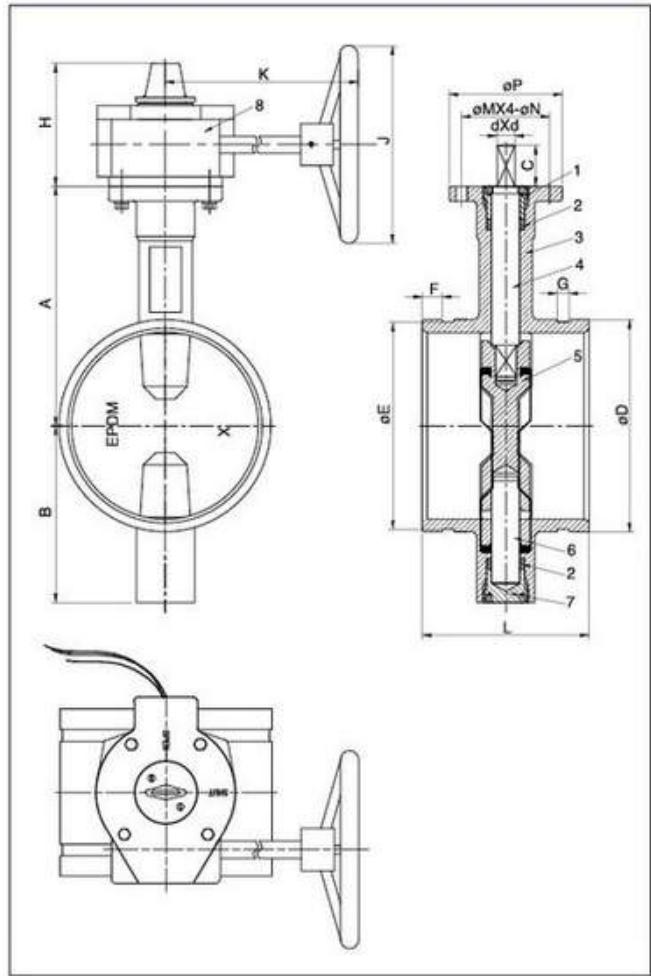

Carried Standard	
Design Standard	API609
Groove Standard	ASME B16.1
Top Standard	ISO5211
Test Standard	API598

SIZE CHART

ITEM SIZE	A	B	C	D	E	F	G	H	K	J	P	M	N	d	L
2-1/2"	125	95	32	76.1	72.1	15.9	7.9	111	218	152	90	70	9	10	96.4
3"	140	100	32	88.9	84.9	15.9	7.9	111	218	152	90	70	9	11	97
4"	160	100	32	114.3	110.1	15.9	9.5	111	218	152	90	70	9	14	115.1
5"	170	125	32	114.3	137	15.9	9.5	111	218	152	90	70	9	14	132.4
6"	190	140	32	168.3	164	15.9	9.5	111	218	200	90	70	9	16	132.4
8"	230	175	32	219.1	214.6	19	11.1	126	232	300	125	102	12	19	147.4
10"	260	200	45	273	268.3	19	12.7	126	232	300	125	102	12	22	159
12"	300	240	45	324	318.3	19	12.7	161	252	350	150	125	14	24	165

08	Signal Gearbox	DI
07	Lower Shaft Sealing Nut	WCB
06	Lower Shaft	SS416
05	Disc	DI+EPDM
04	Upper Shaft	SS416
03	Body	DI
02	Shaft Seal	EPDM
01	Upper Shaft Sealing Nut	WCB
NO.	Name	Material



Technical Specifications:

- 1.Design Standard:AWWA C502
- 2.Nominal Pressure:250PSI
- 3.One pumper nozzle,4.5-4NH thread.Two hose nozzles,2.5-7.5NH threads.Other kinds of threads are available
- 4.Mechanical connector:AWWA/ANSI C153/A21.53 6"

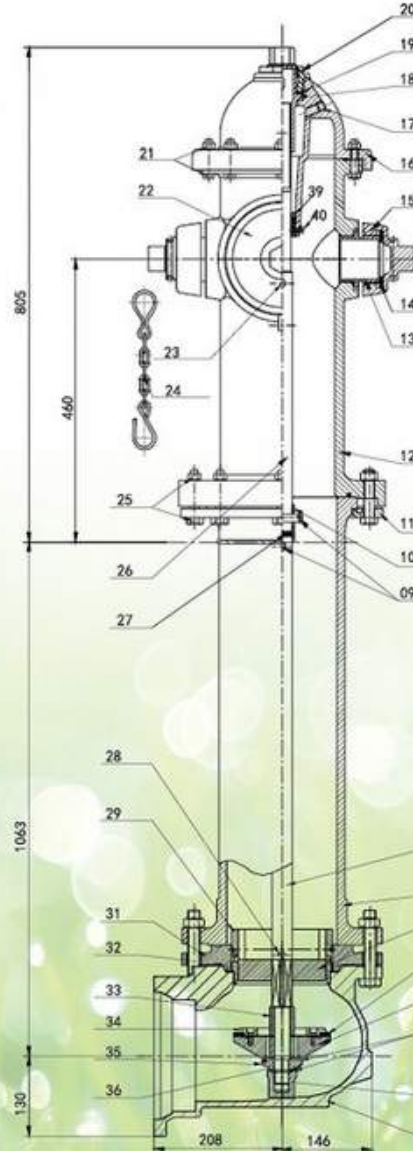

40	Bolt	2	304	ASTM A240
39	Screw Stem Bushing	1	304	ASTM A240
38	100 Cover Gasket	1	EPDM	Figure not shown
37	100 Connector	1	C83600	ASTM B62
36	Check Turn Gasket	1	Gr.B	ASTM A283-B
35	Locking Nut Seat	1	DI	
34	Platen	1	DI	
33	Annular Tubes	1	1045	ASTM A29/29M
32	Bolt- Nut	8	1035	ASTM A29/29M
31	Seat Fixing Plate	1	DI	
29	Seat	1	C83600	ASTM B62
28	Pressure Relief Valve		C83600	ASTM B62
27	Cushion Rubber	1	EPDM	
26	Screw Stem	1	1045	ASTM A29/29M
25	Bolt- Nut	8	1035	ASTM A29/29M
24	Cover Chain	3	Gr.B	ASTM A283-B
23	Cylindrical Pin	1	1045	ASTM A29/29M
22	100 Cover	1	DI	
21	Bolt- Nut	8	1035	ASTM A29/29M
20	Screw Nut Seat	1	C83600	ASTM B62
19	Screw Nut Gasket	1	C83600	ASTM B62
18	Screw Stem Nut	1	C83600	ASTM B62
17	Thread Plug	1	C83600	ASTM B62
16	Upper End Cover	1	DI	
15	65 Cover	2	DI	
14	65 Cover Gasket	2	EPDM	
13	65 Connector	2	C83600	ASTM B62
12	Main Body On Ground	1	DI	
11	Clamp For Connection Tube	1	DI	
10	Connecting Rod Sleeve	1	1045	ASTM A29/29M
09	Perforated Cylindrical Pin	2	1045	ASTM A29/29M
08	Connecting Cylinder	1	DI	
07	Guid Bracket	1	C83600	ASTM B62
06	Sealed Rubber Sheet	1	EPDM	
05	Tray	1	DI	
04	Locking Nut Gasket	1	EPDM	
03	Connecting Rod	1	1045	ASTM A29/29M
02	Locking Nut	1	DI	
01	Mechanical Connector	1	DI	
NO.	Name	Qty.	Material	Remark

VMAL FIRE FIGHTING PRODUCTS



VALVELink
All your process control needs

Công ty TNHH Valvelink

Số 399 Nguyễn Thị Kiều, phường Tân Thới Hiệp,
Quận 12, TP Hồ Chí Minh.

Valvelink (ASEAN)

1-20-02, M-City Ampang, Jalan Ampang, 57450
Kuala Lumpur Malaysia.

Facebook



Website



Zalo



Valvelink (EUROPE)

Hakkı Yeten Cad. Selenium Plaza No:10, 1 Kat:5-6 34349
Fulya Beşiktaş, İstanbul, İstanbul - Şişli, 34349, Turkey.

Valvelink (CHINA)

B Unit 1F A Building No.5 Zi Yang Road Nankai District
Tianjin China.