

Woltman water meter

Woltman Helix water meter can be divided into horizontal Helix Woltman water meter (WPH)

and vertical Helix Woltman water meter (WS) according to different of water meter internal

structure, but the water meters are installed horizontally, The advantage of vertical Woltman water meter (WS) is a wider flow range (R80/R160/R200). The installation does not need the strict requirements of straight pipe section and external filter.

Model: IFLO LXLC-40-900

Use: horizontal woltman water meter is used to measure the total flow of large flow pipeline. It is especially suitable for water supply main pipeline and mining water demand of large plants. The main features are large circulation capacity, small volume, compact structure, easy to use and maintenance.



Applicable conditions :

Size: DN40~DN600

Material: Cast iron shell

Cold water: 0.1 ~ 30 °C

Hot water: 0.1 ~ 90 °C

Working pressure: 1.0MPa

Installation method :

1. Horizontal installation.
2. Additional water filter is required.
3. The water inlet / outlet of the water meter needs straight pipe section U10 / D5.



Characteristics :

1. Dry magnetic transmission structure ensures that the counter is clean and clear.
2. Large flow capacity, small pressure loss and stable performance curve.
3. The measuring movement is replaceable and easy to disassemble.
4. Stainless steel fasteners and epoxy resin powder are sprayed inside and outside the shell to maximize rust prevention and prolong the service life of the product.
5. The measuring mechanism has good universality, magnetic connection, small transmission resistance, sensitive and reliable operation.
6. The counter is vacuum sealed, anti condensation and atomization, and can keep the reading clear and accurate all year round.

Technical parameter :

DN (mm)	Flow range	Maximum flow Q4	Common flow Q3	Boundary flow Q2	Minimum flow Q1	Minimum reading	Maximum reading
	Q3/Q1	m ³ /h			m ³		
40	80	50	40	0.8	0.5	0.001	999,999
50	80	50	40	0.8	0.5	0.001	999,999
65	80	78.75	63	1.4	0.79	0.001	999,999
80	80	125	100	2.0	1.25	0.001	999,999
100	80	200	160	3.2	2.0	0.001	999,999
150	80	500	400	8.0	5.0	0.001	9,999,999
200	80	800	630	12.6	7.88	0.001	9,999,999
250	80	1260	1008	20.16	12.6	0.02	9,999,999
300	80	2000	1600	32	20	0.02	9,999,999
350	80	2800	2240	44.18	28	0.2	999,999,999
400	80	3200	2560	51.2	32	0.2	999,999,999
450	80	3200	2560	51.2	32	0.2	999,999,999
500	80	5000	4000	80	50	0.2	999,999,999
600	80	8000	6400	128	80	0.2	999,999,999

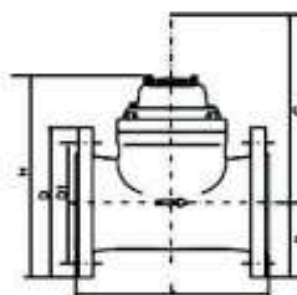

Overall dimension and weight :

DN (mm)	Length	Height	Connection flange			Reference weight
	L ₁ (mm)	H ₁ (mm)	Flange outer diameter	Center diameter of bolt hole D1 (mm)	Number of connecting bolts	kg
40	200	198	150	110	4-M16	8.3
50	200	205	165	125	4-M16	10
65	200	218	185	145	4-M16	12.5
80	225	280	200	160	8-M16	13.6
100	250	290	220	180	8-M16	18.3
150	300	320	285	240	8-M20	28
200	350	365	340	295	12-M20	44.8
250	450	434	450	400	12-M20	80
300	500	459	500	410	12-M24	98
350	500	590	505 / 520	460 / 470	16-M20 / 16-M24	145
400	600	660	565 / 580	515 / 525	16-M24 / 16-M24	199
450	600	700	615 / 640	565 / 585	20-M24 / 20-M27	270
500	800	760	670 / 715	620 / 650	20-M24 / 20-M30	320
600	800	880	780 / 840	725 / 770	20-M27 / 20-M33	520

Indication error curve :

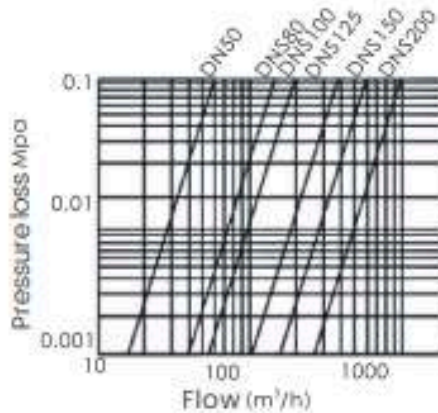

Flow error curve :

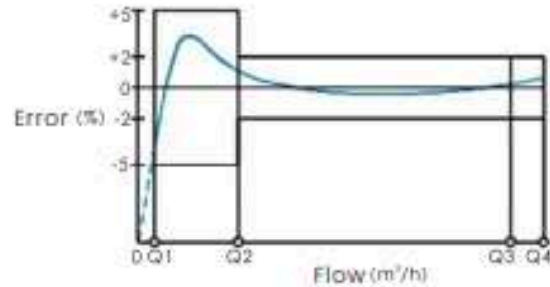

- A. The maximum allowable error of a low area ($Q1 \leq Q < Q2$) is $\pm 5\%$
- B. When the water temperature is $\leq 30^\circ\text{C}$,
the maximum allowable error in the high area ($Q2 \leq Q \leq Q4$) is $\pm 2\%$
When the water temperature is $> 30^\circ\text{C}$,
the maximum allowable error in the high area ($Q2 \leq Q \leq Q4$) is $\pm 3\%$

Model: IFLO WS-40-200

Use: vertical woltman water meter is a kind of woltman (screw wing) water meter. Screw wing water meter, also known as Woltmann water meter, is a kind of speed water meter, which is suitable for use in large-diameter pipeline. It is characterized by large flow capacity and small pressure loss.



Installation method :

1. Horizontal installation.
2. Additional water filter is not required.
3. The water inlet / outlet of the water meter does not need the requirements of straight pipe section.

Material: Cast iron shell
 Applicable conditions:
 Cold water: 0.1 ~ 30 ℃
 Hot water: 0.1 ~ 90 ℃
 Working pressure: 1.0MPa

Characteristics :

1. No worm gear transmission mechanism, impeller directly drives counter, high transmission efficiency and low starting flow.
2. Wide range, suitable for occasions with large flow change.
3. Full flow detection, high measurement accuracy.
4. Dry magnetic transmission structure ensures that the counter is clean and clear.
5. The six digit enlarged digital wheel displays the reading, and the reading is clearer.
6. The detachable metering movement structure is convenient for maintenance.
7. Internal adjustment structure to prevent private meter adjustment.
8. Built in stainless steel filter screen effectively protects the measuring mechanism.
9. The high wear-resistant bearing system (gem bearing for aviation instrument + high wear-resistant cemented carbide shaft) ensures the long-term stability and reliability of the product and significantly improves the maximum flow of the product.
10. Stainless steel fasteners and epoxy resin powder are applied inside and outside the shell to maximize rust prevention and prolong the service life of the product; Optional anti prying protective cover (prevent users from disassembling the movement without permission, damaging or changing the measuring mechanism, and play the role of anti-theft water to the greatest extent).

Technical parameter :

DN (mm)	Flow range	Maximum flow Q4	Common flow Q3	Boundary flow Q2	Minimum flow Q1	Minimum reading	Maximum reading
	Q3/Q1	m ³ /h					
40	50/200	50	40	1.28 / 1.25	0.8 / 0.2	0.0001	999,999
50	50/200	50	40	1.28 / 1.25	0.8 / 0.2	0.0001	999,999
80	50/200	80	63	2.0 / 2.0	1.26 / 0.32	0.0001	999,999
100	50/200	125	100	3.2 / 3.12	2.0 / 0.5	0.0001	999,999
150	50/200	312	250	8.0 / 7.88	5.0 / 1.25	0.0001	999,999
200	50/200	500	400	12.8 / 12.5	8.0 / 2.0	0.0001	999,999

Overall dimension and weight :

DN (mm)	Length		Height		Connection flange			Reference weight
	L (mm)	H (mm)	h (mm)	Flange outer diameter	Centerdiameter ofboothole D1 (mm)	Numberof connectingbolts	kg	
40	280	228	85	150	110	4*M16	11.6	
50	280	228	85	165	125	4*M16	12	
80	370	282	103	200	160	8*M16	21.3	
100	370	303	114	220	180	8*M16	25	
150	500	430	155	285	240	8*M20	68.2	
200	500	505	190	340	295	12*M20	99.8	

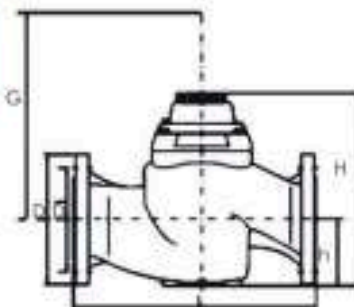

Indication error curve:

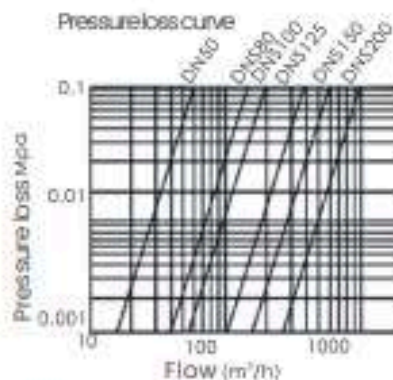
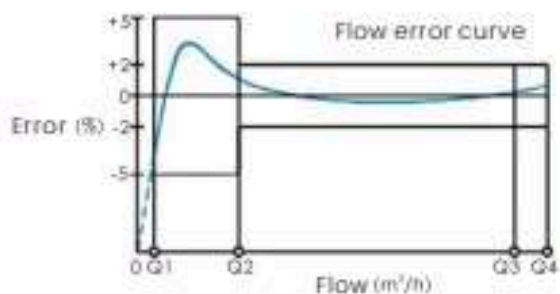

- A. The maximum allowable error of a low area ($Q1 \leq Q < Q2$) is $\pm 5\%$
- B. When the water temperature is $\leq 30^\circ\text{C}$,
the maximum allowable error in the high area ($Q2 \leq Q \leq Q4$) is $\pm 2\%$
when the water temperature is $> 30^\circ\text{C}$,
the maximum allowable error in the high area ($Q2 \leq Q \leq Q4$) is $\pm 3\%$