

# BT-16

## INVERTED BUCKET STEAM TRAP

### GENERAL FEATURES

Ayvaz BT-16 Inverted Bucket Steam Traps have high strength construction structure so they are durable for water hammer.

The same diameter steam traps have different orifice diameters for evacuation of variable loads.

Inverted Bucket Steam Traps evacuate the condensate when it appears that's why their heat efficiency is high.

When the steam enters the steam trap, steam moves upwards to the bucket. Steam traps close with the closing system which is fixed to bucket so steam exist in the bucket. Because of the heat loss at steam trap body, steam becomes condensate and bucket moves downward. Steam trap opens with the valve system which is fixed to the bucket and condensate is evacuated.

#### Applications

- Heat exchangers
- Heating units
- Radiator panels
- Vulcanizing equipment
- Drying coils
- Rubber presses
- Main fuel tank heaters
- Horizontal lines

Ayvaz BT-16 inverted bucket system has to be filled halfway with water at the first operation. Orifice and counterpart are made of hardened stainless steel. Strainers should be used before the steam traps.

#### Connection:

Threaded and Flanged

#### Pressure Range:

Max. 16 bar

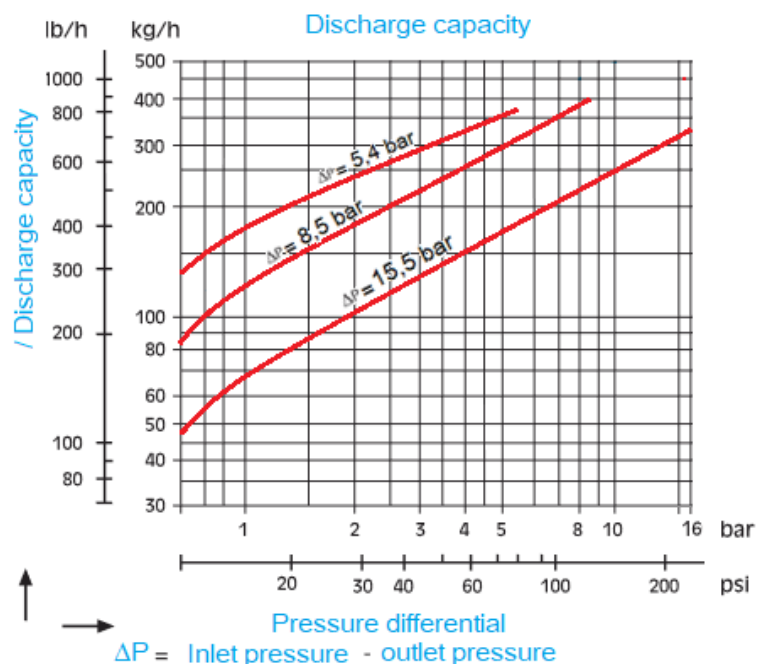

# BT-16 INVERTED BUCKET STEAM TRAP

Material List		
No	Part Name	Material
1	Body	GGG 40
2	Adjustment Pipe	Stainless Steel AISI 304
3	Filter	Stainless Steel 304
4	Body Plug	St 37-2
5	Cover Gasket	Grafit
6	Bushing	Stainless Steel AISI 304
7	Cover	GGG 40
8	Fixed Seat	Stainless Steel AISI 304
9	Screw	Stainless Steel AISI 304
10	Seat	Stainless Steel AISI 304
11	Valve	Stainless Steel AISI 304
12	Valve Seat	Stainless Steel AISI 304
13	Washer	Stainless Steel AISI 304
14	Locking Washer	Stainless Steel AISI 304
15	Float	Stainless Steel AISI 304
16	Cover Plug	St 37-2
17	Bolt	8.8

### Installation and Precautions:

- Clean the residues, dust and other foreign matter in the pipeline before installation.
- Install in an easily accessible place.
- Install the device close to the device.
- Make the pipeline sloped so that water can flow through the gravity into the condensate.
- Set up a bypass pipe.
- Make sure that the output line does not rise to prevent backflow.
- Make sure that it is connected horizontally.

Dia.	Applicable differential pressure (bar)
1/2" - 3/4" - 1"	5.4/8.5/15.5
Body	GGG 40
Cover	GGG 40
Inner Part and Float	Stainless Steel
Max. Working Pressure	16 bar
Max. Working Temp.	220 °C
Connection	Threaded

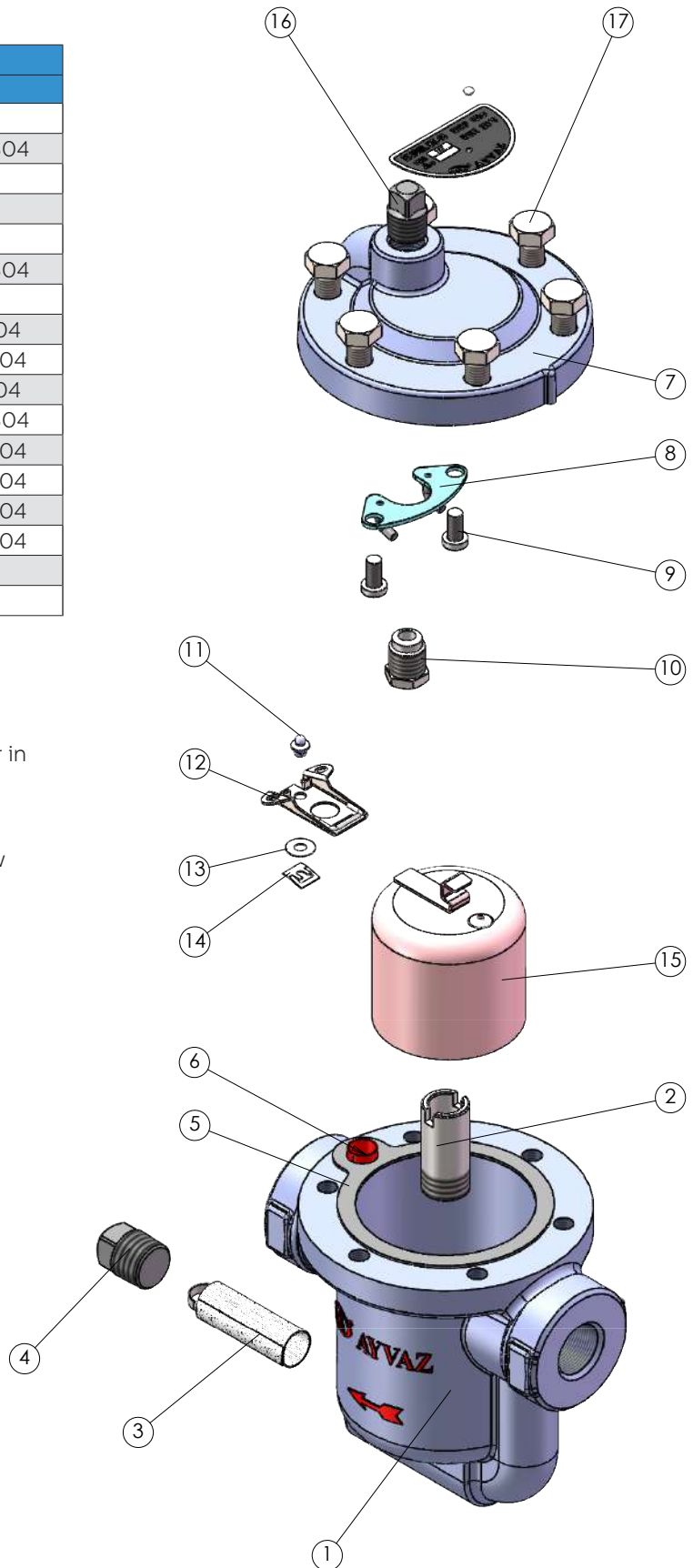

# BT-16 INVERTED BUCKET STEAM TRAP

## THREADED TYPE SPECIFICATIONS

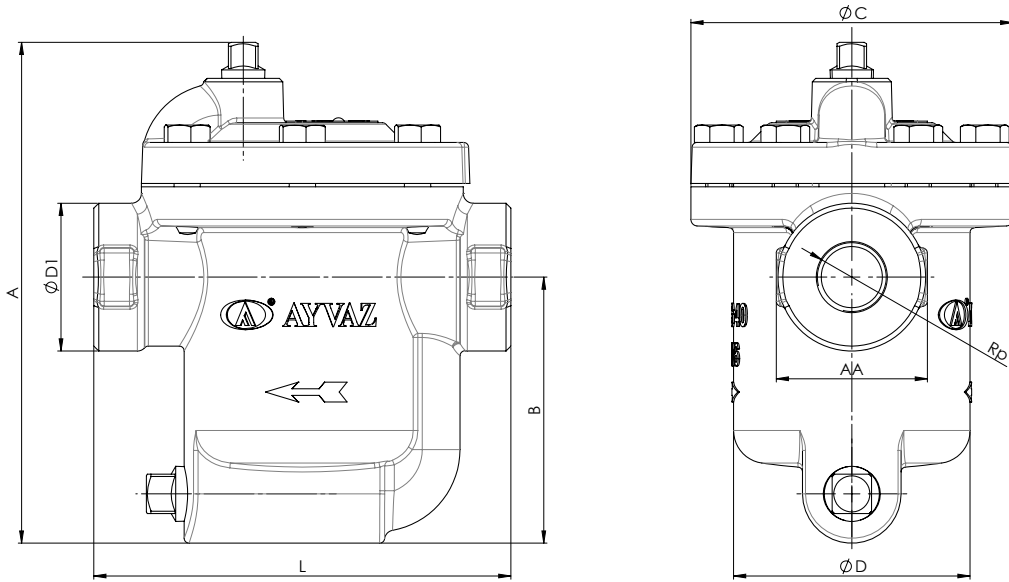

Dia.	A	B	ØC	ØD	ØD1	L	AA
1/2"	153	81	98	72	45	127	46
3/4"	153	81	98	72	45	127	46
1"	183	103	98	72	55	127	56

All dimensions are in "mm".

## FLANGED TYPE SPECIFICATIONS

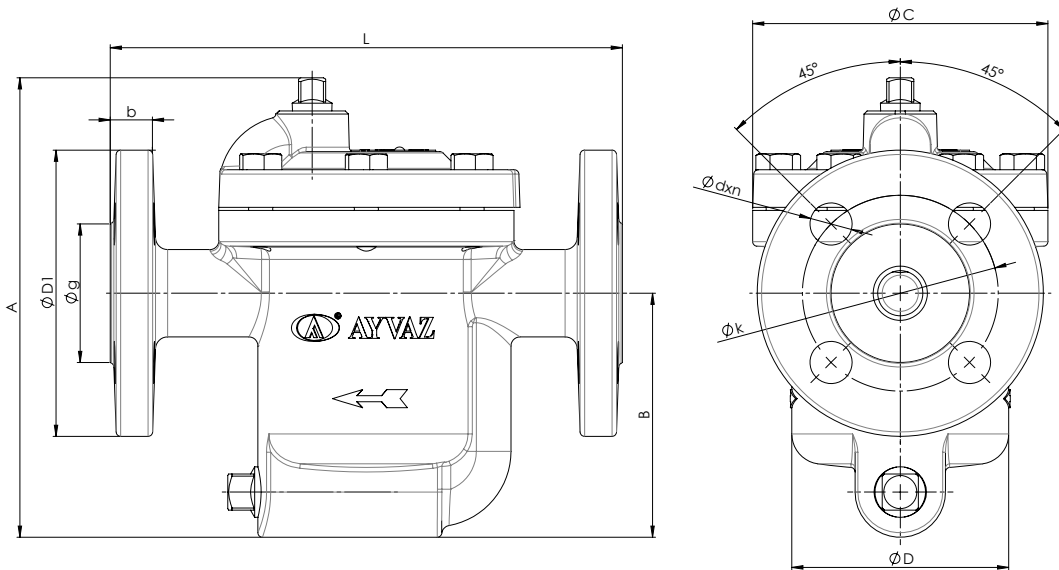

DN	A	B	ØC	ØD	ØD1	L	Øk	Øg	b	Ødxn
15	153	81	98	72	95	170	65	46	14	Ø14x4
20	153	81	98	72	105	180	75	56	16	Ø14x4
25	183	103	98	72	115	195	85	65	16	Ø14x4

All dimensions are in "mm".

# BT-16 INVERTED BUCKET STEAM TRAP

## Storage and Handling:

Consider the following recommendations to maximize product performance.

- Do not overload on it.
- Do not store the product in dusty or high humidity areas.
- Do not allow foreign substances to enter the product.
- Sand particles, deposits etc. that may come into contact with the gasket during pipe installation or cleaning. Please do not allow such materials.
- Close valves 1 and 2 to clean the bypass line.
- Do not perform a water pressure test on a valve which may cause water leakage or malfunction.

SIGN	REASON	SOLUTION
No Discharge	the orifice is clogged with dirt	Dismantling and cleaning
	If the pressure used is higher than the condensate pressure	Replacement with condensate at proper pressure
	If there is insufficient discharge	Exchange with sufficient capacity steamtrap
Low Discharge	Extreme counter pressure and insufficient working pressure difference ( $\Delta P$ )	The inlet / outlet outlet pressure / pipe is reconsidered.
	if the filter at the inlet of the steamtrap is blocked	Dismantling and filter cleaning
Steam Leak	If there is dirt between disk and seat	Disassembly, disc and seat cleaning
	Worn disk and seat	Disc and seat replacement
	Defective by-pass valve	Change the by-pass valve

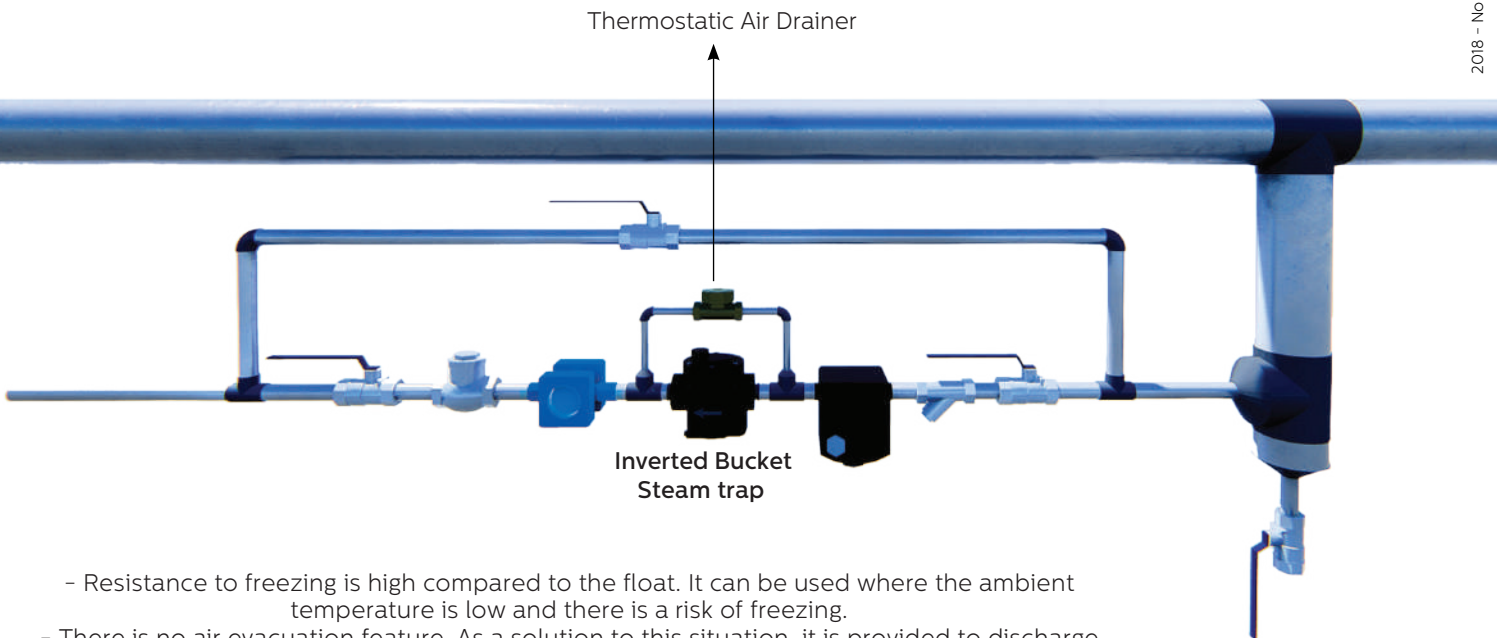

- Resistance to freezing is high compared to the float. It can be used where the ambient temperature is low and there is a risk of freezing.
- There is no air evacuation feature. As a solution to this situation, it is provided to discharge the air by putting a thermostatic air drainer as in the application example.

## BT-16 INVERTED BUCKET STEAM TRAP

## BT-16 INVERTED BUCKET STEAM TRAP



### HEAD OFFICE - FACTORY

Atatürk Sanayi Bölgesi Hadımköy Mahallesi Mustafa İnan Caddesi No: 44 Arnavutköy - İSTANBUL  
Tel: +90 212 771 01 45 (pbx) | Fax: +90 212 771 47 27  
info@ayvaz.com | www.ayvaz.com

#### **Cona Caserta/Italy**

Tel: +39 0823 187 3988  
rmolaro@ayvaz.com

#### **Ayvaz Germany Viernheim/Germany**

Tel: +49 62046014399  
germany@ayvaz.com

#### **Ayvaz Ukraine Kiev/Ukraine**

Tel: +380 44 390 57 57  
info@ayvaz.com.ua

#### **Tricorr Warsaw/Poland**

Tel: +48 530 030 810  
+48 533 603 335  
tricorr@tricorr.eu

#### **Ayvaz Azerbaijan Baku/Azerbaijan**

Tel: +99 (455) 579-84-32  
ahayatov@ayvaz.com

#### **Ayvaz Egypt Cairo/Egypt**

Tel: +20 122 819 78 29  
andrew.eid@ayvaz.com

#### **Ayvaz Gulf Dubai/U.A.E**

Tel: +971 563550822  
+971 501306871  
mideast@ayvaz.com

#### **Ayvaz China Ningbo/China**

Tel: +86 152 5830 7361  
msahin@ayvaz.com

#### **Ayvaz Kazakhstan LLP Almaty/Kazakhstan**

Tel: +7 (727) 327 97 57  
info\_kz@ayvaz.com

#### **Ayvaz N Ispirih/Bulgaria**

Tel: +359 8431 27 32  
office@ayvaz-n.eu

#### **Ayvaz Serbia Belgrade/Serbia**

Tel: +381 61 658 70 52  
yakbiyik@ayvaz.com

#### **Ayvaz Vietnam HCMC/Vietnam**

Tel: +84 89 8508345

#### **Ayvaz Americas Rhode Island/USA**

Tel: +1 401 737 8380  
americas@ayvaz.com