

ISEN-FQ10

Float continuous level gauge

Insertion-type float continuous liquid level meter is a product designed, developed and produced by our company in accordance with chemical standards (HG/T2742-95). It is a level meter with dual functions of remote control and local indication and on-site monitoring. Insertion-type float continuous liquid level meter can effectively overcome the false liquid level formed by suspended matter, foam, etc., and is particularly ideal for liquid level measurement in closed containers, underground tanks or high-level water tanks.



Product Features

1. Continuous monitoring of liquid level with high repeatability;
2. Independent of foam and conductivity, and not affected by liquid specific gravity and pressure;
3. A variety of different materials to meet the needs of different sites;
4. Convenient remote control and simple connection with control unit or digital display instrument;
5. The indicating mechanism is completely isolated from the measured medium, so it has good sealing and safe use;
6. Easy maintenance, clear and wide readings are brighter, more accurate and reliable;
7. The measurement range can be made according to the actual requirements of the user

Working Principle

The reed switch and the precision resistor are evenly fixed in a sealed nonmagnetic conduit. When the float ball with a hollow interior and a ring-shaped magnetic steel fixed therein floats up and down along the conduit under the buoyancy of the liquid, the reed switch changes the resistance value of the circuit under the action of the magnetic force. The analysis and processing components in the circuit detect the change in the resistance value and convert it into a standard signal output of 4-20mA to achieve continuous control of the liquid level.

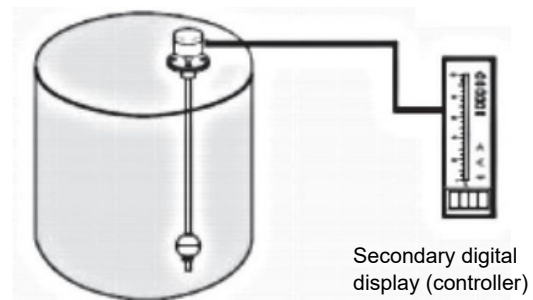

Insertion type float continuous level gauge

Application Field

Float continuous level gauges are widely used in petrochemical, food processing, environmental protection, electric power and other industries. The specific application scenarios are as follows: Petroleum industry: In the fields of oil exploration, oil production, oil storage, oil transportation, etc., to achieve liquid level monitoring and oil level control of storage tanks, pipelines, oil wells and other equipment; Chemical industry: Widely used in large containers such as storage tanks, reactors, separators, etc., for real-time monitoring of liquid levels; Food processing industry: Float level gauges are used in food processing equipment, storage tanks, mixers and other occasions to monitor and control the liquid levels of raw materials, liquid foods, beverages, etc.;

Application Field

Environmental protection field: In large sedimentation tanks and other equipment, it can monitor and control sewage water levels; it can also be used in environmental protection fields such as dam water level and reservoir water level monitoring and sewage treatment; Power industry: Float level gauges are used in cooling towers, boilers, generator sets and other equipment to monitor and control the liquid levels of cooling water, supplywater, etc.;

Product Line

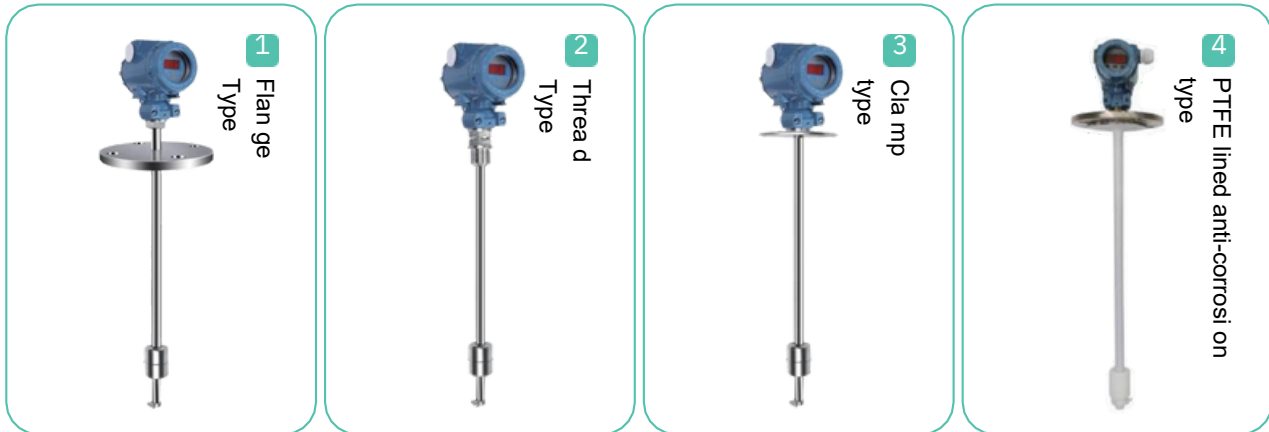

Technical Specification

Measuring Range	300~6000mm Intrinsic Error: $\pm 1\%$ FS (Full Scale)
Power Supply	24VDC
Output	4~20mA two-wiresystem, 4-20mA HART two-wire system
Accuracy	Standard $\pm 5\text{mm}$
Operating Temperature	-20~80°C (Maximum withstand temperature: 120°C)
Pressure Rating	$\leq 10\text{Mpa}$
Ingress Protection Rating	IP65
Explosion-Proof Rating	Ex(ia) II BT4
Wetted Parts Materials	SUS304, SUS316L, PP, PTEE, and other materials
Connection Type	Flange, Thread, Clamp, and other types available

Instructions

1. For level gauges longer than 3 meters, the conduit should be positioned at the bottom of the tube to increase its strength and stability;
2. The medium in the tank (especially around the conduit) is not allowed to have magnetic conductors and magnetic impurities to avoid blocking the float and affecting the normal operation of the level gauge;
3. Do not adjust ZERO (zero point) and SPAN (full scale) at will (they have been adjusted at the factory);
4. Avoid strong collisions with the level gauge to avoid damage to the level gauge

Outline Dimension Drawing (Reference)

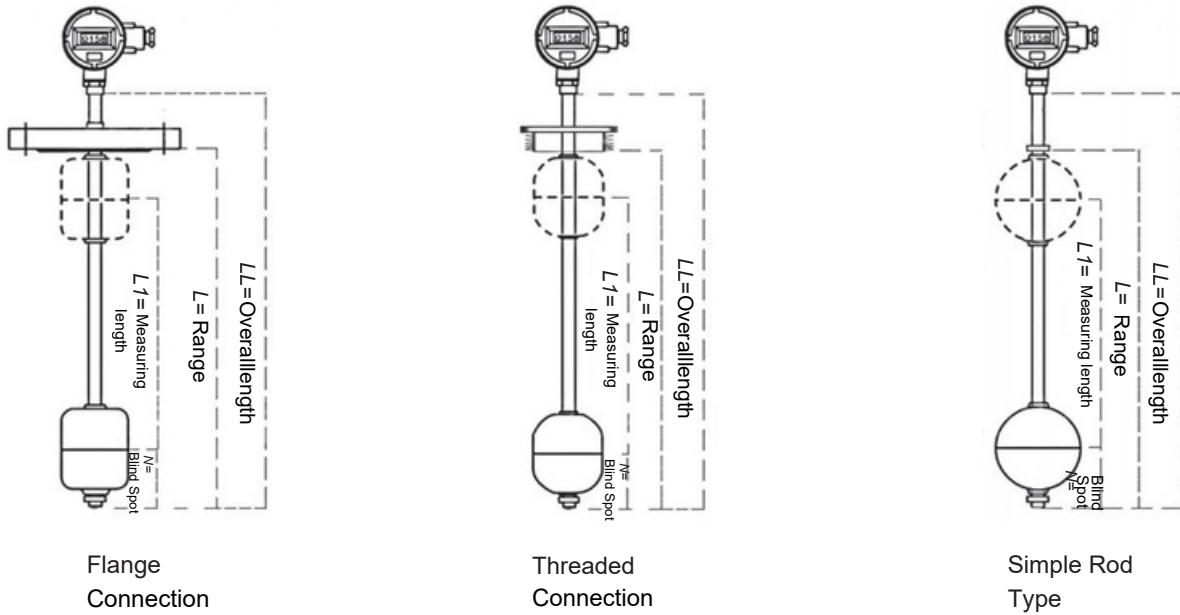

Note: $L \text{ range} = L1 \text{ measuring length} + N \text{ blind zone}$
 (blind zone length $\leq 100\text{mm}$) $LL \text{ total length} = L$
 insertion length + 50mm ($\pm 30\text{mm}$).

Installation Style

Thread size, insertion depth, and flange size can all be customized

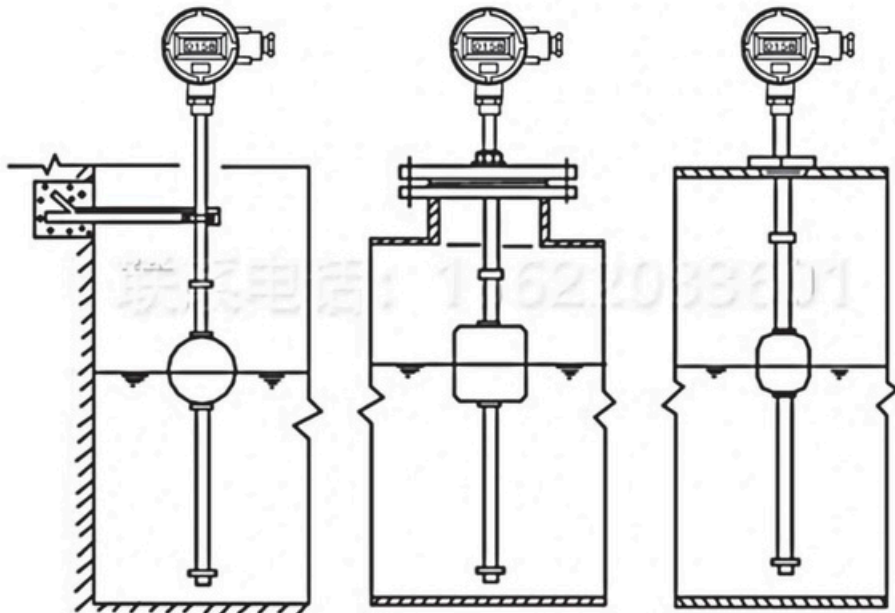

Rack mount

Flange fixation

Threaded connection

Terminal block diagram

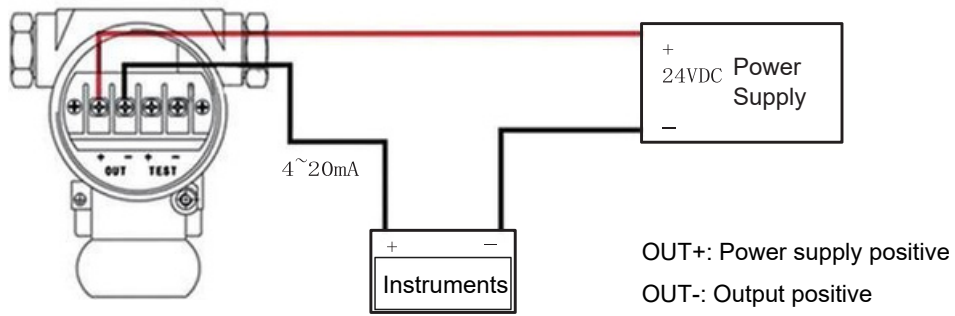

Two-wire connection

Installation Instructions

1. The installation location should be far away from the medium inlet and outlet to reduce the impact of medium fluctuations on it.

2.If the switch is installed in the stirring area, a wave-proof tube or wave-proof baffle can be installed

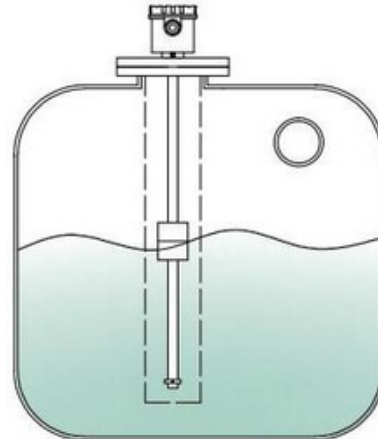
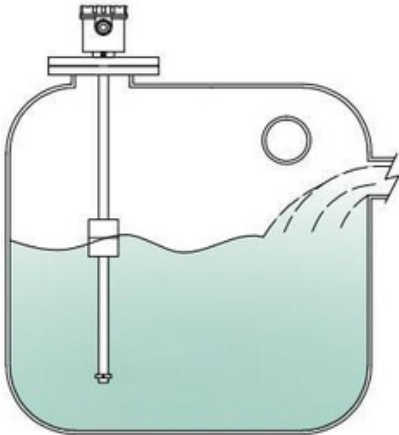

3.The switch is installed on the concrete pool wall and an L shaped angle iron bracket can be installed.

4.Select a flange connection pipe with a diameter larger than the float diameter.

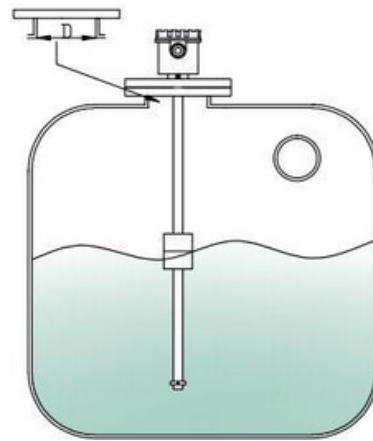
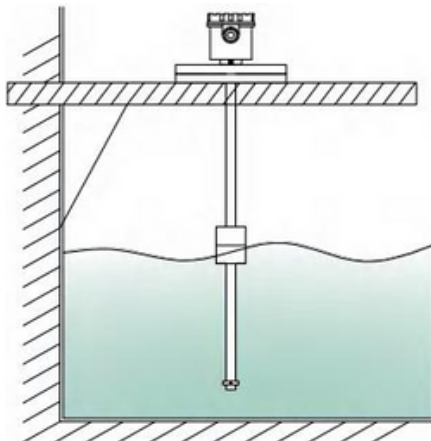

Magnetic float selection table

*Special specifications of float can be customized

Size	φ×H×d (mm)	Material	Density(g/cm ³)	Temperature Resistance(°C)	Pressure Resistance (Kg/cm ²)	Diagram
S1	φ40×H36×d15.5	SUS304, 316L	0.7	150	10	
S2	φ40×H50×d15.5	SUS304, 316L	0.7	150	10	
S3	φ45×H56×d15.5	SUS304, 316L	0.7	150	10	
S4	φ30×H29×d9.5	SUS304, 316L	0.65	150	25	
S5	φ52×H52×d15.5	SUS304, 316L	0.65	150	25	
S6	φ75×H75×d15.5	SUS304, 316L	0.55	150	25	
S7	φ125×H125×d15.5	SUS304, 316L	0.45	150	25	
P1	φ40×H52×d20	PP	0.65	75	5	
P2	φ48×H52×d20	PP	0.65	75	5	
F1	φ55×H70×d23	PVDF	0.85	150	5	
F2	φ40×H52×d20	PVDF	1.0	150	5	

Selection Chart

Mode		Product Name	
ISEN-FQ10		Float continuous level gauge	
Code	Explosion-proof		
P	Standard type (non-ex plosion-proof)		
E	Explosion-proof type		
	Code	Measuring Range	
	xxxx	300~ 6000mm (custom range selection required)	
	Code	Process Connection	
	S	G1-1/2" Threaded connection	
	F	DN50 Flange conn ection (standard)	
	T	Clamp connection	
	SK	Adjustable threaded connection	
	FK	Adjustable flange connect ion	
	Code	Wetted Material	
	S	SUS304	
	L	SUS316L	
	P	Polypropylene (PP)	
	F	PVD F (Polyvinylidene Fluoride)	
	Code	Temperature Range	
	T	-20~80°C	
	H	-20~120°C	
	Code	Float Size	
	S1~F2	Refer to magnetic float selection table	

Selection Chart (Continued)

	Code	Wiring Method
	1	(4~20) mA two-wire
	2	(4~20)mA + HART two-wire
	3	(4~20) mA +RS485 two-wire
	Code	Housing Material
	L	Aluminum alloy
	P	Polypropylene (PP)
	Code	Display
	1	With Display
	0	No Display

Selection Example

Example: ISEN-FQ10-E500SLTS12L1, float continuous level gauge, explosion-proof, range 500mm, G1-1/2" thread installation, liquid contact material SUS316L, temperature -20~80°C, float size S1 φ40×H36×d15.5 material SUS304, 316L density 0.7g/cm3, wiring method (4~20)mA +HART two-wire system, housing aluminum alloy, with display.



Valvelink Co., Ltd. (VIETNAM)

Address: 399 Nguyen Thi Kieu Street, Tan Thoi Hiep Ward, Ho Chi Minh City, Vietnam
 Hotline: +84 933 603 406
 WhatsApp: +84 979128773
 Email: contact@valvelink.vn / tech@valvelink.vn
 Website: valvelink.vn

Valvelink Europe Ent (EUROPE)

Address: Via Roma 108, Cassina de Pecchi, 20060, Milan, Italy
 Hotline: +90-2123818702
 WhatsApp: +84 979128773 / +84 933 603 406
 Email: sales@valvelink.eu
 Website: valvelink.eu

Website



WhatsApp



Valvelink Sdn Bhd (ASEAN)

Address: 1-20-02, M-City Ampang, Jalan Ampang, 57450 Kuala Lumpur, Malaysia
 Hotline: +60-173700361
 WhatsApp: +84 979128773 / +84 933 603 406
 Email: sales@valvelink.asia
 Website: valvelink.asia

Boon (tianjin) Environment Technology Industry Co.,Ltd. (CHINA)

Address: Unit B, 1F, Building A, No. 5 Ziyang Road, Nankai District, Tianjin, China
 Hotline: +84 979128773
 WhatsApp: +84 933 603 406
 Email: sales@valvelink.asia
 Website: valvelink.com.cn